

TunnelTech 201

Road Tunnel Atmosphere Monitoring Systems

CO, NO and Visibility Monitor

- Continuous measurement of CO, NO and Visibility in road and rail tunnels
- Class leading Accuracy, Repeatability and Resolution
- Rugged, corrosion resistant construction
- Minimal maintenance requirements
- PC based software for commissioning and maintenance
- Optional RS 485 (Modbus) Output

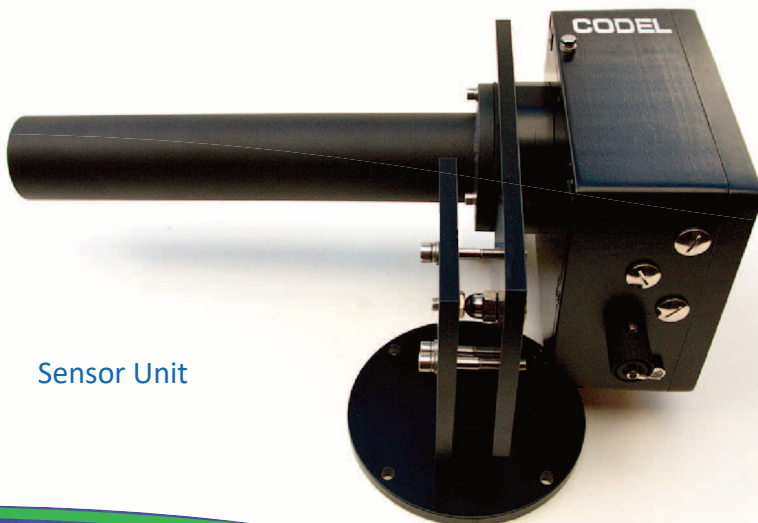

Sensor Unit



Optional Data Display Unit

ISO 9001:2015

Quality Certification

ISO 14001:2015

Environmental Certification

TunnelTech 201 - Air Quality Monitor

The TunnelTech 201 Air Quality Monitor, is an essential part of any road or rail tunnel safety system. Firstly, it monitors the atmosphere within the tunnel and ensures that the tunnel ventilation system provides sufficient clean air to protect tunnel users health and for drivers to clearly see the road ahead.

The TunnelTech 201 analyser uses well proven infra-red techniques to determine CO and NO concentrations and optical attenuation to monitor Visibility levels. As there is only one moving part, reliability levels are very high and maintenance requirements are extremely low. The sight tubes have been designed to ensure that airborne dust and contaminants do not reach the optical windows and cause drift.

Fully configurable analogue and alarm outputs are exportable to the tunnel data acquisition system to provide real-time CO, NO and Visibility data. This data may also be exported via the optional RS485 serial port which delivers MODBUS RTU encoded data to a SCADA system located in the tunnel control centre and/or a local display module. In addition, IP65 rated enclosures are constructed to resist attack from aggressive gases, road salt and the effects of heat.

In areas where extremely low temperatures may be experienced, optional transmitter and receiver insulation jackets are available to reduce the effect.

There are three versions of the TunnelTech AQM available;

- a) TunnelTech 201 CO, NO and Visibility monitor
- b) TunnelTech 202 CO and Visibility monitor
- c) TunnelTech 203 CO and NO monitor
- d) TunnelTech 204 Visibility monitor

CODEL's tunnel sensor range is further extended by additional sensors for the measurement of NO₂ and tunnel airflow.

Please see these additional product data sheets:-

TunnelTech 301 Air Flow Monitor - For the measurement of wind speed and direction

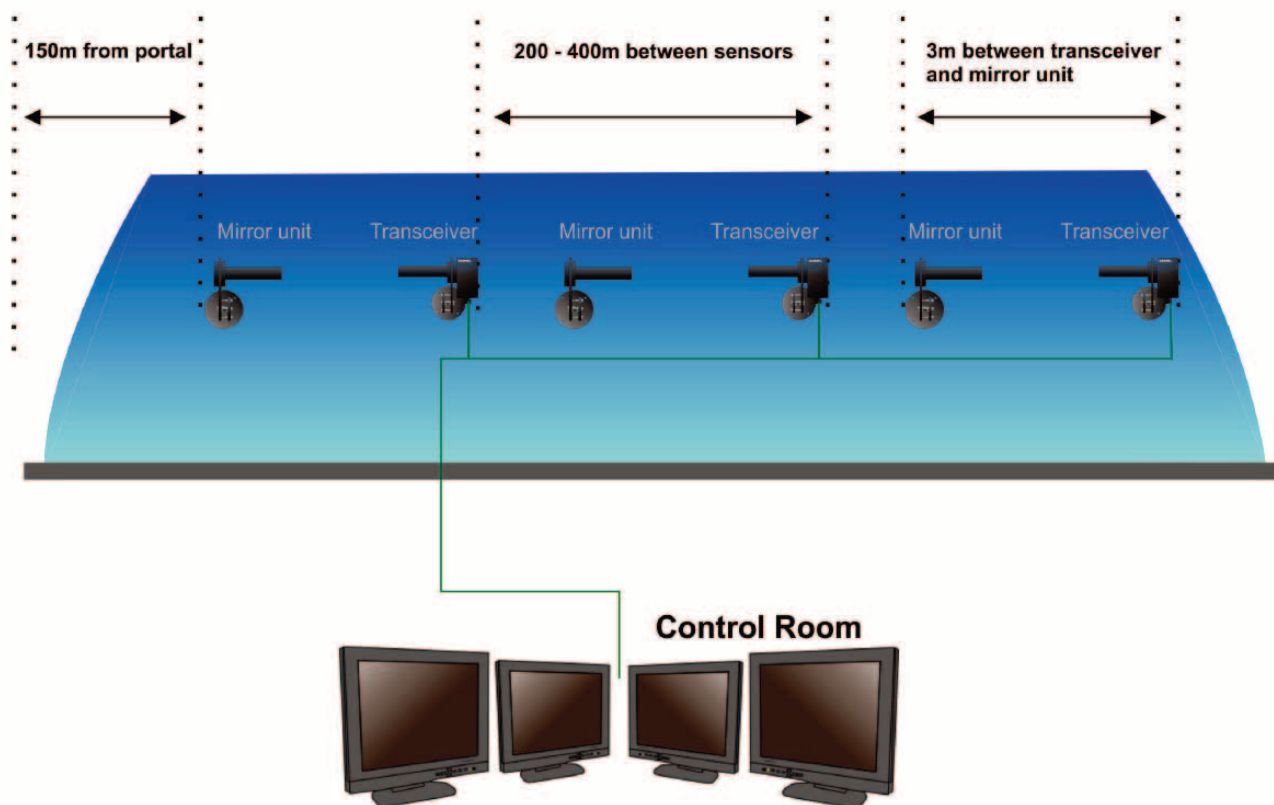

TunnelTech 201- Air Quality Monitor - System Arrangement



mA Outputs

Relay Outputs

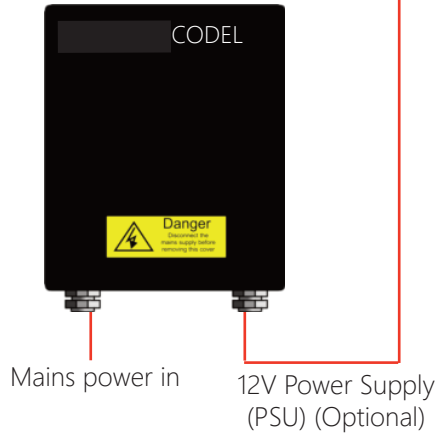

----- Temporary commissioning equipment -----



RS232/485 Communications Unit*



CODEL TunnelTech Software*

*RS232/485 Communications Unit and TunnelTech Software are required for commissioning and maintenance use.

TunnelTech Software

- Easy installation and set-up
- Will operate on any Windows based operating system
- User friendly Alignment Mode to aid initial set-up and optical alignment
- Allows sensor configuration settings to be adjusted
- Fault diagnostic logging for sensor troubleshooting

TunnelTech Software is supplied with all CODEL Tunnel Sensor's as standard for the purpose of commissioning and maintenance of the sensors. With simple installation and set-up routine to any Windows based laptop PC, the program takes only minutes to load and configure and comes with a comprehensive on-board help feature.

The software enables the sensor's complete data and control functions to be accessed via a PC using either an RS232 or optional RS485 communications box, also supplied with the sensor.

A built-in alignment feature aids the initial set-up and commissioning routine by giving a display of the detector signals to the engineer to ensure that optical alignment is maximised and the sensor operates to its optimal performance

Zero calibrations and span checking using a CODEL Check filter can be initiated via the software after commissioning or a maintenance period. Should it be necessary to alter the initial factory-set current and relay output configuration then this can also be carried out with ease.

For maintenance the software includes short-term logging and trending of diagnostic data for fault analysis.

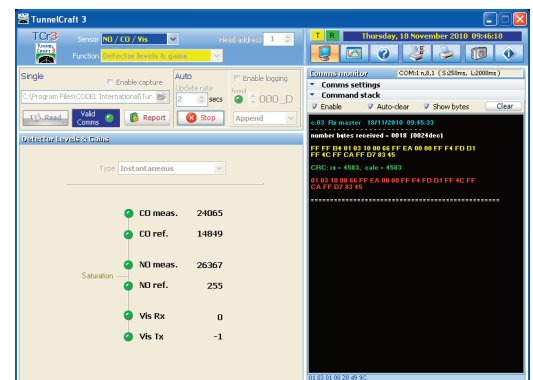
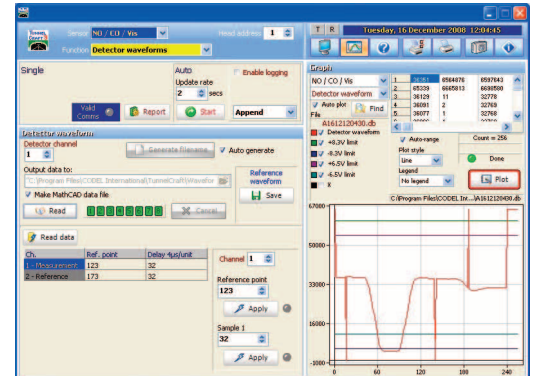

Communication Interfaces



RS232 Unit



RS485 Unit

Key Design Parameters

Open path optical absorption technology used by CODEL has proved to be very accurate and reliable. For maximum performance however certain key design parameters need to be optimised.

Path length

There is often a misconception that measurements over a longer path length will produce a more accurate reading because more gas is being measured. If the optical beam was highly focused, like a laser beam for example, then this would be the case. However such a beam would be extremely sensitive to alignment, resulting in a very unreliable measurement.

As a result, open path measurement systems use an optical arrangement in which a broader beam of energy is used to desensitise the impact of optical misalignment. The result of this is that the energy received by the sensing element reduces with the square of the path length, thereby reducing the signal/noise ratio of the measurement as path length is increased.

We thus have two conflicting elements that determine the overall accuracy of an open path measurement system. Basic measurement sensitivity increases with path length, while signal/noise ratio reduces with the square of the path length. Increasing the path length to achieve higher sensitivity will simply result in a noisier signal, with the noise increasing faster than the measurement sensitivity.

The compromise solution to this dilemma is to select the shortest path length consistent with achieving the required measurement sensitivity. Increasing the path length beyond this point brings no added value, only a noisier signal, and increases difficulties with alignment stability.

CODEL measure CO, NO and Visibility over a path length of 3 metres using a folded beam arrangement, giving a total path length of 6 metres. This enables the accuracy requirements for all three channels to be comfortably satisfied. Sensors from other manufacturers require longer path lengths (typically 10 metres) to achieve their specified accuracy. We view this as a disadvantage due to increased measurement noise and optical alignment sensitivity.

A further disadvantage of a long optical path length is that when measuring gases, the sensitivity of measurement decreases with the amount of gas measured, because of saturation effects of the gas infra-red spectrum. It is thus not possible to maintain accuracy over a wide measurement range when using a long path length. For example at a 10 metre path length (20 metre folded beam) the measurement uncertainty over the range 150 to 300ppm CO will be more than twice that over the range 0 to 150ppm. The CODEL sensor can maintain its accuracy over the full operating range of 0 to 300ppm.

Choice of infrared detector

To avoid the problems of operating a long pathlength in order to achieve the required sensitivity CODEL utilise a very high quality thermo-electrically cooled lead selenide detector. This enables an accuracy for CO measurement of 1ppm to be maintained over a 3 metre folded beam path for the range 0-300ppm. Contrast this with other manufacturers sensors, utilising less sophisticated and cheaper pyroelectric detectors, having an accuracy specification of only 5ppm over a 10 metre path for the range 0-150ppm and 12ppm for the range 150-300ppm.

Intelligent design and value engineering of the total system achieve the cost effectiveness of the CODEL solution. No compromises on component quality are tolerated.

Measurement of NO

Use of the lead selenide detector also enables CODEL to integrate a measurement channel for NO into the tunnel sensor, a result not possible with pyroelectric detectors. The CODEL sensors are unique in their ability to provide three key measurements, CO, NO and Visibility in one compact sensor.

TunnelTech 201 - Dimensions

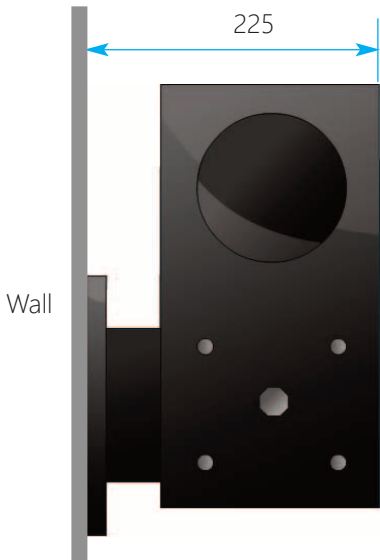
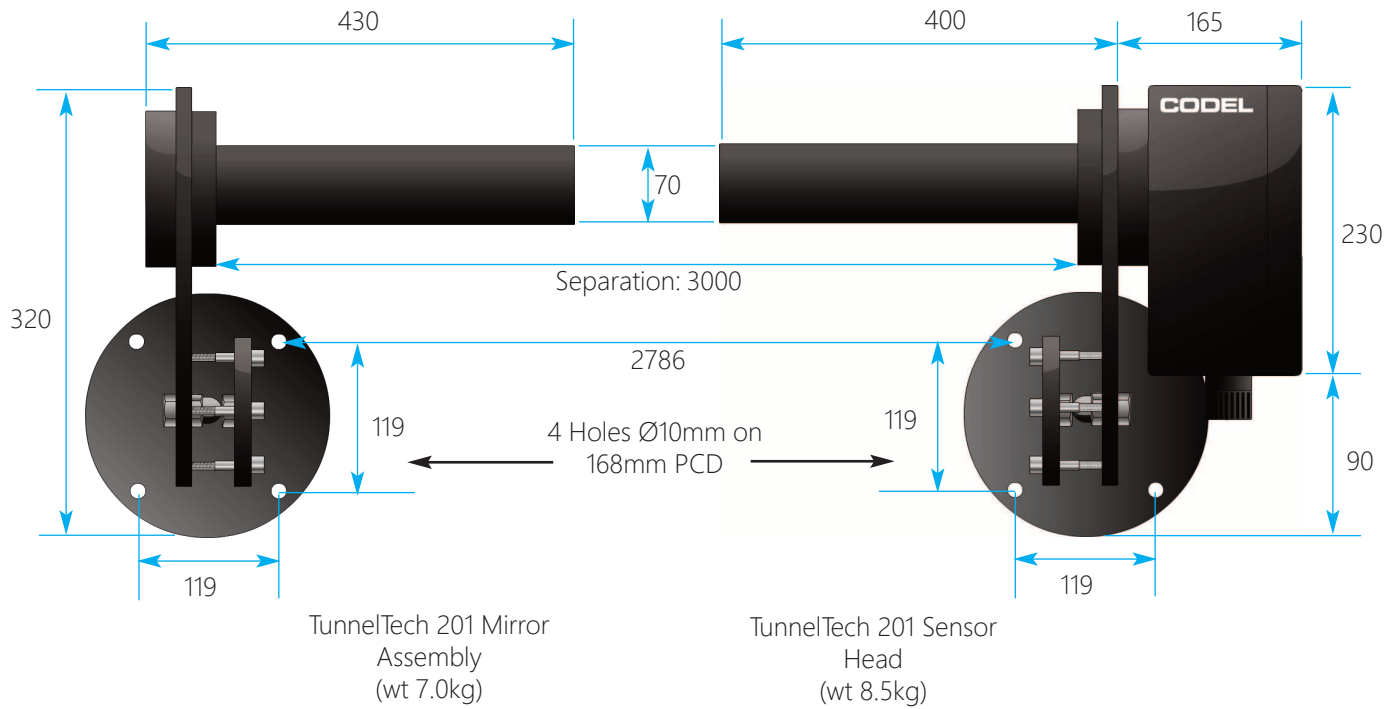

Note: All dimensions are in mm

Overall Dimensions - Power Supply Unit & Tunnel Display Unit (Optional)

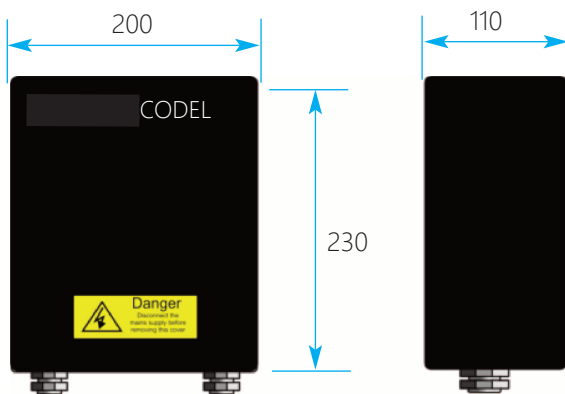

Power Supply Unit (PSU) (wt 4kg)

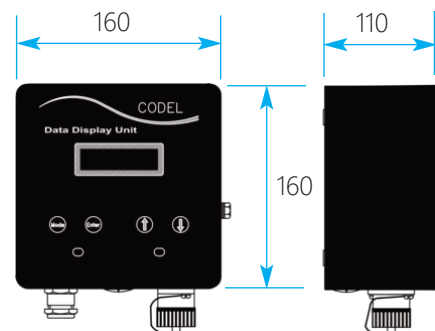

Tunnel Display Unit (TDU) (wt 2kg)

Note: All dimensions are in mm

TunnelTech 201 Air Quality Monitor - Technical Specification

Sensor Unit

Gas Species Options	Single or multi-gas measurements available: CO, NO & Visibility		
Measuring units	ppm for CO & NO, m ⁻¹ or m for visibility		
Path Length	3m (6m folded beam)		
Calibration	Automatic zero calibration - manual span check by sealed check cell		
Measurement	Carbon Monoxide (CO)	Nitric Oxide (NO)	Visibility
Measurement Technique	Infrared Gas Cell Correlation	Infrared Gas Cell Correlation	Optical Transmissivity
Measurement range (typical*)	CO 0 - 100ppm	NO 0 - 30ppm	0 - 0.015 m ⁻¹
Accuracy	CO +/- 1ppm or 2% of span	NO +/- 2ppm or 2% of span	Vis +/- 0.0002 m ⁻¹
Resolution	CO +/- 1ppm	NO +/- 1ppm	Vis +/- 0.0001 m ⁻¹
Response Time	CO 2mins	NO 2mins	Vis 10s - 2min Selectable
Ambient Temperature	-20°C to +50°C		
Power supply	12V DC, 20 VA from separate power supply. Optional 24V DC available upon request		
Construction	Corrosion resistant epoxy coated aluminium housing sealed to IP66		

*Other measurement ranges available on request

Compliances

EMC	EN61326-1:2006 & EN50270:2006 directive compliant
Low Voltage	73/23/EEC directive compliant

Communications & Outputs

Analogue outputs	3 x 4-20mA current outputs as standard, isolated, 500Ω maximum load, fully configurable through TunnelTech software.
Relay Outputs	3 x volt-free SPCO contacts, 50V, 1A maximum load, configurable as alarm contacts
Communications Port	For local connection to laptop PC using RS232 or optional RS485 interface unit

Services

Power	12V DC @1.5A/ 24V @ 2.5A
-------	--------------------------

Optional Items

Power Supply	90/264V AC, 47-63Hz, 60W 12V DC @5A (or 24V DC @ 2.5A)
Check Cell Holder	For manual span check using sealed check cell
Sealed Check Cell	CO & Visibility span check optical cell
Flow Through Check Cell	NO span check using bottled audit gases
Tunnel Display Unit	For local display of sensors outputs
Serial Data	RS485 Modbus Protocol

Distributor

CODEL International Ltd
Unit 4
Station Road
Bakewell
Derbyshire
DE451GE
United Kingdom

Tel : +44 (0)1629 814351
Fax : +44 (0)8700 566307
Web : www.codel.co.uk
Email : sales@codel.co.uk